



DSM FRP FAN

SPECIFICATIONS

CONSTRUCTION

FRP (Fiber Reinforced Plastic) is used as the material of the fan casing with Blade material can be FRP or Aluminium.



DRIVEN MOTOR

We have brushless DC motor makes the performance more stable and superior. This kind of negative fan adopts 220V brushless DC motor drive, with large air flow, small energy consumption, long using life, stable operation and other outstanding features.



MOTOR AND CONTROLLER

Motor protection class is IP 55, Insulation Class F. Whisper quite, direct-drive, variable speed control.



ENVIRONMENT

Wet-rated for indoor or outdoor use IPX5.

VOLT AND FREQUENCY

Customized Production: With phase Failure protective device to ensure motor working well.

SHUTTER

Shutters, corrosion resistant, anti-aging. Shutters close automatically, anti-raining and anti-dust.



FRAME

Semi-Automatic PET Bottle Blowing Machine Bottle Making Machine Bottle Molding Machine, PET Bottle Making Machine is suitable for producing PET plastic containers and bottles in all shapes.



DIMENSIONS

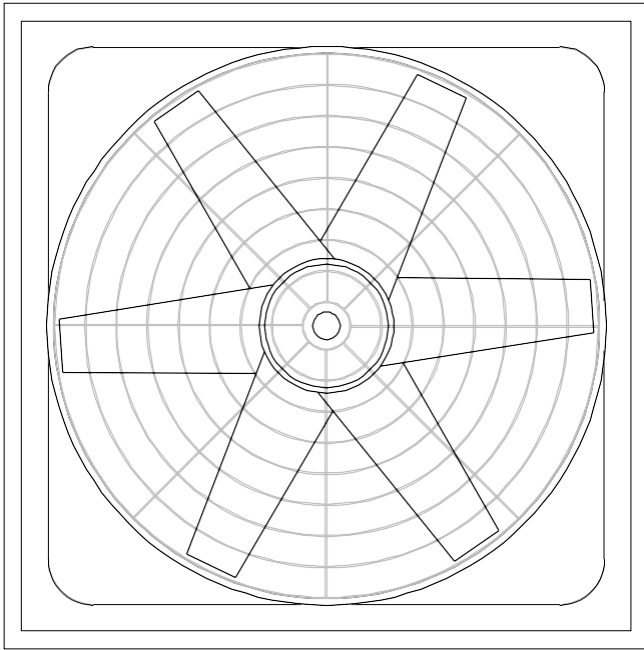

Front Elevation View

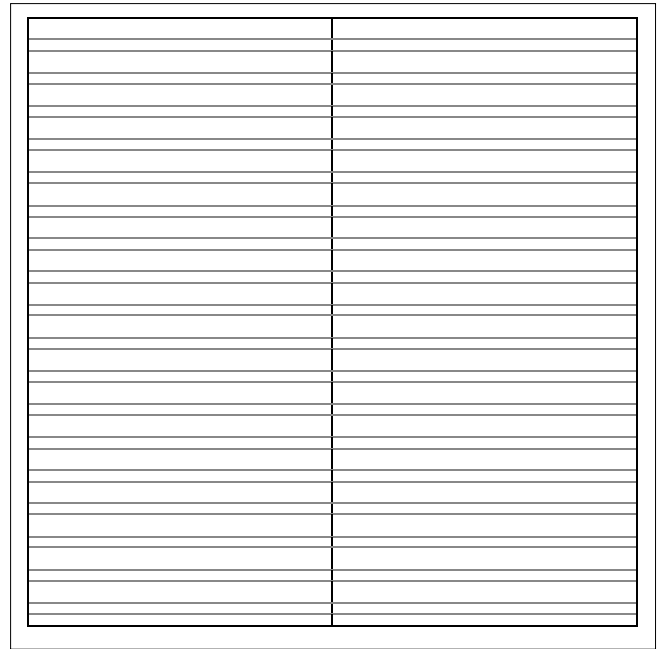

Back Elevation View

FRP EXHAUST FAN

Model	Dimensions (mm)	Power (w)	Air Flow	Voltage / Frequency	Noise	Rotation Speed	Net Weight
DSM 850	850*850*480 mm	370 W	28000 m ³ /h (467 m ³ /min or 16500 CFM)	380V/50Hz	< 53 DB	620 rpm	35 kg
DSM 1060	1060*1060*550 mm	550 W	35000 m ³ /h (533 m ³ /min or 19000 CFM)	380V/50Hz	< 55 DB	560 rpm	45 kg
DSM 1260	1260*1260*560 mm	750 W	37000 m ³ /h (620 m ³ /min or 22000 CFM)	380V/50Hz	< 65 DB	560 rpm	55 kg
DSM 1460	1460*1460*580 mm	1.1 KW	45000 m ³ /h (750 m ³ /min or 26500 CFM)	380V/50Hz	< 65 DB	560 rpm	65 kg



Five Stars



Stability



Safety



Easy Maintenance



Power Saving



Cost Effective



Artistic



Convenience



Intelligence



Performance

OUR OTHER EQUIPMENTS

- ‡ Centrifugal Blower
- ‡ Axial Flow Fan
- ‡ Bag Filter
- ‡ Cyclone

- ‡ Wet Scrubber
- ‡ Dry Scrubber
- ‡ Spiral-Round Duct
- ‡ Rectangular Ducting

- ‡ Air Washer
- ‡ ESP Fume Collection Unit
- ‡ ESP Oil Collection Unit
- ‡ Flat-Oval Ducting



DUSTECH



DUSTECH ENGINEERS PVT. LTD

Plot No. 7 B, 13/3 Mile Stone, Mathura Road, Faridabad-121001 [HR.] INDIA

Ph. : +91 129 4158076 E-mail: Dustech@rediffmail.com, Sales@dustech.in

Web: www.Dustech.in